

# Southeast Toyota Parts Distribution

## Packaging Standards

## **PALLETIZATION/MASTER PACK GUIDELINES**

1. Standard pallet footprints to be used for all shipments are:

<b><u>Length x Width</u></b>	<b><u>Tolerance</u></b>
48" x 30"	+0", -1/2"
48" x 45"	+0", -1/2"
48" x 60"	+0", -1/2"

Note: The footprint shown is the outside dimension of the length and width of the pallet.

2. The pallet footprint dimensions are as follows:

Length: The length of the deck boards or primary pallet access dimension  
Width: The length of the notched 2" x 4" stringer

3. The pallet design must be flush stringer design and allow for 4-way entry on all pallet sides.
4. The standard pallet dimensions must be adhered to whenever possible. SET Parts Distribution must approve any pallet not adhering to these standards.
5. All palletized loads should utilize the full pallet master package shipping container with wooden support piers with a static load of 10,000 lbs. as illustrated below:

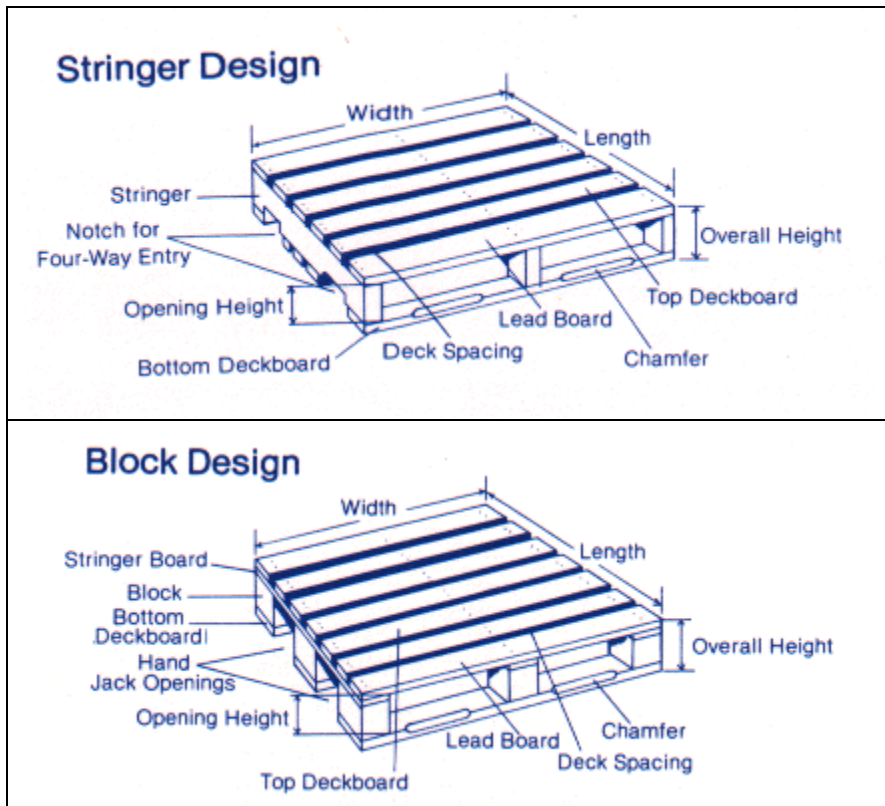

- 6. Acceptable palletized master package load height maximum is 48 inches. Shrink wrap used to secure packages to pallets must be **clear**. SET Parts Distribution must approve any deviation from these standards.
- 7. Requests to ship in other than a wooden support pier pallet must be made to SET Parts Distribution.
- 8. Product shipped in other than wooden support pier pallet must adhere as closely as possible to the load height maximum of 48 inches and withstand a minimum static load of 10,000 lbs.
- 9. Gaylords and palletainers will need to be reviewed and tested by SET Parts Distribution upon request.

**D. LABELING REQUIREMENTS**

- 1. The available label formats for identification on unit part shipments are shown below. Parts received by SET without proper labels may be rejected and subject to return. Failure to apply the appropriate labels will also be factored into SET's supplier assessment scorecard.
  - a. Small Unit Label – This label should only be used on unit part packages too small to apply the standard unit label without folding or creasing the bar code.



Small Unit Label

Standard Unit Label – This label is required for all unit packaged parts.

DESCRIPTION	<b>BLACK BUMPER PROTECTOR</b>
PART NO	<b>00015-SC202</b>
	
QUANTITY	<b>1</b>
U.S.A 22G1	

Standard Unit Label

Intermediate Label – Identical specs to Standard Unit Label without manufacturing country and date code. Quantity measurement is always greater than one.

DESCRIPTION	<b>BLACK BUMPER PROTECTORS</b>
PART NO	<b>00015-SC202</b>
	
QUANTITY	<b>10</b>
U.S.A 22G1	

Intermediate Unit Label



Details of Standard Unit Label

7. The manufacturing location print size shall be 7 LPB in Arial font type shown in the example above.
8. The part number size shall be 2 LPB (lines per block, 32 points) and in Arial font type shown in the example under paragraph # 9 above. **Human readable part numbers should use a hyphen as part number separator and alpha characters must be in uppercase.**
9. The specifications for printing the bar code on the label are listed below:
  - a. The bar code shall be code 39.
  - b. An asterisk (\*) shall be used as the start and stop code and shall be put at the beginning and the end of a bar code part number.
  - c. The barcode part number shall consist of 12 digits. **NO HYPHENS (-)** or any other type of separator should be used in the barcode. The entire length of the bar code shall be 2.25 inches wide.
  - d. The height of the bar code shall be 0.5 inches.
  - e. The bar code shall be printed on medium density.
10. The proper positioning of the unit part number label on the unit carton is illustrated below.
11. Affix the part number unit label to the flat surface of a bag/wrap or on the end panel of a carton as shown below. Note label must be on a flat surface and bars perpendicular to the natural bottom of the container, or attached to the part on a tag when no flat surface is available.

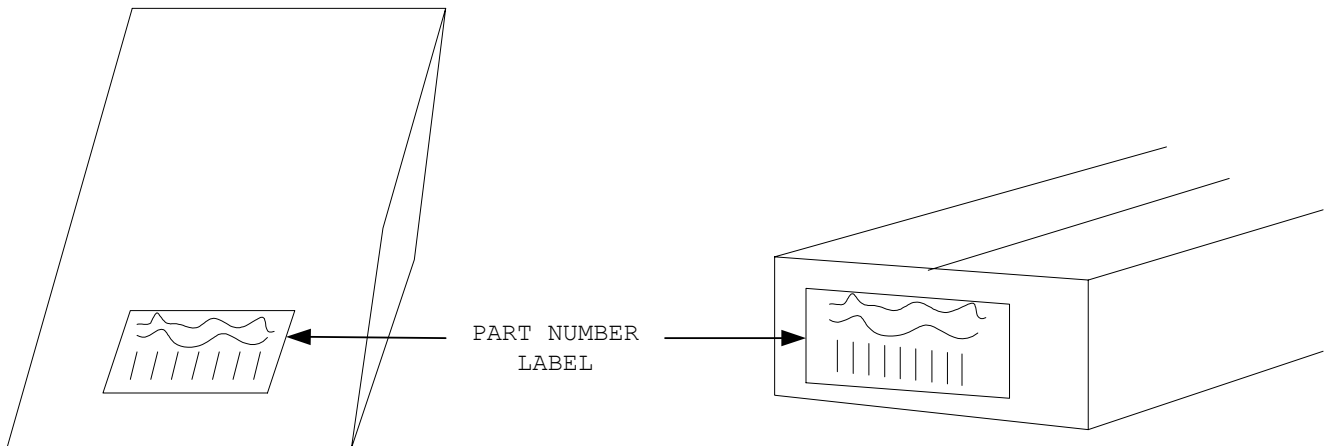

**PARTS LABEL STANDARD PLACEMENT**

12. If the space available on the carton end panel is not adequate, affix the label to the top panel as shown below.

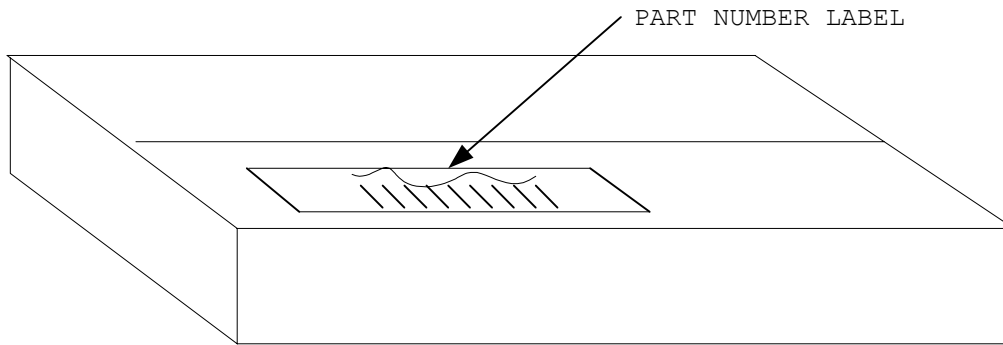

### PARTS LABEL OPTIONAL PLACEMENT

13. Under no circumstances is the part number label to be folded over two panels
14. Under no circumstances is the part number label to be taped over when sealing a package, even when using clear tape.
15. The date code as shown above is to be located in the lower right hand corner of the unit label.
16. Size of the date code if printed in conjunction with other label information should be 7 LPB.
17. Date code must be coded as follows:

Requirement: 4 digit/letter code as described below.



**22**      **G**      **1**  
 Day of Month      Month of Year\*  
 Year (2001)

Jan=A, Feb=B, Mar=C, Apr=D, May=E, Jun=F, Jul=G, Aug=H, Sep=I, Oct=J, Nov=K, Dec=L

18. The font and bar coding requirements to be used on the intermediate label should be the same as that of the standard unit label specifications.
19. SET case label specifications.
  - a. Bar coded case labels are required on each pallet/master pack shipped from the supplier and will act as an electronic packing list. The following is a summary of key formatting rules for these standards required for the SET Case Label.
    - (1) Building Block Size – The block height should be 1.0” +/- 0.2” (25mm +/- 5mm) as determined by the printing capability of the label printer. The width of the building block is the width of the label.
    - (2) Text Requirements – A sans serif font such as Arial is preferred. **All alpha characters must be in uppercase.** Height is defined in Lines Per Block (LPB). Three sizes are acceptable for the SET label. See LPB table.
    - (3) Bar Code Requirements – A title should be included in the building blocks that contain bar codes. The title shall be printed in the upper left corner of the building block with text height of at 6 LPB. The bar code height should be 0.5” inches and width 2.25 inches.

- (4) Symbology – For part barcode in the case label, code 39 bar code symbology shall be used as defined AIM Uniform Symbology Specification Code 39 (USS - Code 39). Detailed specifications of Code 39 can be found on the internet at [Code 39 Specifications](#) for further reference. The barcode part number shall consist of 12 digits. **NO HYPHENS ( - ) or any other type of separator should be used in the barcode.** For a 10-digit part number, the 11<sup>th</sup> and 12<sup>th</sup> digits shall be filled with spaces. The entire length of the bar code shall be 2.25 inches wide.
- (5) Label Size/Stock – Label may be any size large enough to contain the date in the proper format, and can be larger than required, if cost effective. Label size recommendations are 6.0" x 4.0" .

b. Case Label – The SET version case label shall consist of three building blocks.

<b>PART NO</b> <b>00015-SC202</b> 		← (1) Top building block <ul style="list-style-type: none"> <li>• TITLE = 6 LPB, Arial</li> <li>• PART NUMBER= 2 LPB, Arial</li> <li>• BARCODE = 2.25" x .5", Code 39</li> </ul>
<b>QUANTITY</b> <b>40</b>	ELW Corporation Street address City, State, Zip	← (2) Second building block <ul style="list-style-type: none"> <li>• TITLE = 6 LPB, Arial</li> <li>• QUANTITIES= 2 LPB, Arial</li> <li>• SUPPLIER ADD = 6LPB, Narrow Arial</li> </ul>
<b>CASE #</b> <b>S7R12345</b> 		← (3) Third building block <ul style="list-style-type: none"> <li>• TITLE = 6 LPB, Arial</li> <li>• CASE NUMBER= 2 LPB, Arial</li> <li>• BARCODE = 2.25" x .5", Code 39</li> </ul>

Case Label

- (1) The top building block should contain the SET part number with bar code. The text height for the part number should be 2 LPB (lines per block, 32 points) and should contain hyphen(s) as part number separators. The part number is printed in the bar code. Bar code height is 0.5" and width is 2.25 inches. The title for the block is human readable Part Number \*\*.

\*\* When the case contains multiple part numbers, the Part Number block shall read "**MIXED LOAD**". Text height shall be 2 LPB.

- (2) The second building blocks should contain two sub-blocks, side by side.

- **(LEFT)** Quantity of parts in the case\*\*. No bar code is required. The text height is 2 LPB.

\*\* When the label is "**MIXED LOAD**", quantity shall be **BLANK**.

- **(RIGHT)** Supplier name and ship from address. No bar code. Text height 6 LPB.

(3) The third building block should contain the 8 characters and human readable unique case number. Bar code height is 0.5” and width is 2.25 inches.

- The 3-character prefix shall be the unique trading partner number assigned to each supplier by SET. **All alpha characters must be in uppercase.**
- The last characters can be alphanumeric and shall be a case number assigned by the supplier, must remain unique for at least two years from the time SET received the case. Case number assigned can be up to 5 characters and no more than 5 characters. Numbers are preferred, however if letters are used in the case ID, **THEY MUST BE IN UPPERCASE** and SET recommends that they be used in the beginning of the case number. No symbols or special characters should be used. The text height shall be 6 LPB. The title shall be “Case #”.
- A check digit at the end of the 8-digit case number shall be included on the barcode.
- Similarly to part barcodes, case barcodes must be Code 39 and should begin and end with an asterisk (\*).

c. Case Label Shipment Application

- (1) The case label is used by SET to identify parts on each pallet of a supplier's shipment.
- (2) Each pallet of a supplier's shipment must have a case label and it's own unique case number. Two pallets with the same case number are NOT acceptable and will be rejected.
- (3) The physical case label should follow the SET specification requirements as stated in paragraph 19 of this document.
- (4) The case label should be placed on the upper right position **outside on top of clear shrink wrap at the forklift access** side of the pallet as shown below:

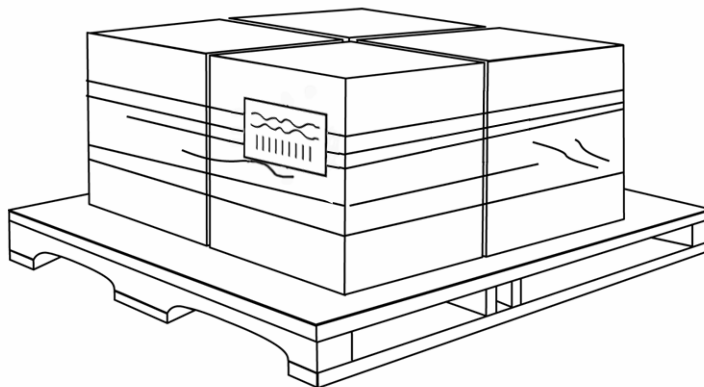

(sample palletized case)

- (5) Case label data should be included on the shipment packing list information accompanying the shipment to clearly show which SET part numbers and quantities are in each case.

(6) This information is used for invoicing and payment.

(7) Mixed load cases will be organized with like part numbers grouped or packed together.  
Random placement of parts palletized with a mixed load label will result in a compliant infraction.

---

**F. CORRECTIVE ACTION REPORT**

<b>SHIPMENT</b>	<b>SOURCE DOC#</b>	XXXXXXXXXXXXXXXXXX
Supplier Name: XXXXXXXXXXXXXXXXXXXX.	SET-PDC	Date: XXXXXXXX
Packing Slip Number	Source Name	TIME:
XXXXXXXXXXXXXXXXXXXX	PO Number/ASBN	Writer Name
XXXXXXXXXXXXXXXXXXXX	XXXXXXXXXXXXXXXXXXXX	TIME:
Carrier Name: XXXXXXXXXXXXXXXXXXXX	Phone:	NAME:
Carrier Shipment Number/BOL	Receiver Signature:	
X   X   X   X   X   X   X   X   X   X	Drivers Signature	

**PROBLEM DESCRIPTION**

**Supplier Issue**

- s01. No labels
- s02. Incorrect labels
- s03. Barcode part number does not match readable part number
- s04. Barcode part number is not SET number
- s05. Barcode case label does not match
- s06. No barcodes
- s07. Unscannable bar codes
- s08. Improper wrap , crushed shipment, top heavy
- s09. Missing packing list/shipping papers
- s10. Shipped to wrong destination
- s11. Broken QUP's
- s12. Overage
- s13. Shortage
- s14. Label location not in compliance
- s15. Parts damaged
- s16. Incorrect packing list
- s17. Incorrect invoice
- s18. Parts not palletized
- s19. Wrong parts shipped
- s20. Shipment pallet height non-compliant. (max. load height is 48 inches)
- s21. ASBN shipment errors (ie..typos, missing data, inaccurate data)

**Carrier Issue**

- c1. Split shipments
- c2. In-transit damage
- c3. Broken wrap, crushed shipment, top heavy
- c4. Shipped to wrong destination
- c5. Broken QUP's
- c6. Lost in transit

o1. Other

